

## TFT LCD Approval Specification

# MODEL NO.: M185B1-L02

Customer:	_____
Approved by:	_____
Note:	

- CONTENTS -

REVISION HISTORY .....	3
1. GENERAL DESCRIPTION .....	4
1.1 OVERVIEW	
1.2 FEATURES	
1.3 APPLICATION	
1.4 GENERAL SPECIFICATIONS	
1.5 MECHANICAL SPECIFICATIONS	
2. ABSOLUTE MAXIMUM RATINGS .....	5
2.1 ABSOLUTE RATINGS OF ENVIRONMENT	
2.2 ELECTRICAL ABSOLUTE RATINGS	
2.2.1 TFT LCD MODULE	
2.2.2 BACKLIGHT UNIT	
3. ELECTRICAL CHARACTERISTICS .....	7
3.1.1 TFT LCD MODULE	
3.1.2 Vcc Power Dip Condition:	
3.2 BACKLIGHT UNIT	
4. BLOCK DIAGRAM .....	11
4.1 TFT LCD MODULE	
4.2 BACKLIGHT UNIT	
5. INPUT TERMINAL PIN ASSIGNMENT .....	12
5.1 TFT LCD MODULE	
5.2 LVDS DATA MAPPING TABLE	
5.3 BACKLIGHT UNIT	
5.4 COLOR DATA INPUT ASSIGNMENT	
6. INTERFACE TIMING .....	15
6.1 INPUT SIGNAL TIMING SPECIFICATIONS	
6.2 POWER ON/OFF SEQUENCE	
7. OPTICAL CHARACTERISTICS .....	17
7.1 TEST CONDITIONS	
7.2 OPTICAL SPECIFICATIONS	
8. PACKAGING .....	20
8.1 PACKING SPECIFICATIONS	
8.2 PACKING METHOD	
9. DEFINITION OF LABELS .....	22
10. PRECAUTIONS .....	23
10.1 ASSEMBLY AND HANDLING PRECAUTIONS	
10.2 SAFETY PRECAUTIONS	
11. MECHANICAL CHARACTERISTICS .....	24

**REVISION HISTORY**

Version	Date	Section	Description
Ver 3.0	Oct,29, 08'		M185B1-L02 Approval specification was first issued.

## 1. GENERAL DESCRIPTION

### 1.1 OVERVIEW

M185B1-L02 is a 18.5" TFT Liquid Crystal Display module with 2 CCFL Backlight unit and 30pin 1ch-LVDS interface. This module supports 1366 x 768 WXGA mode and can display up to 16.7M colors. The inverter module for Backlight is not built in.

### 1.2 FEATURES

- Contrast ratio 1000:1
- Response time 5ms.
- Brightness 250nits
- Color saturation NTSC 72%.
- WXGA (1366 x 768 pixels) resolution.
- DE (Data Enable) only mode.
- LVDS (Low Voltage Differential Signaling) interface.
- RoHS compliance.

### 1.3 APPLICATION

- TFT LCD Monitor

### 1.4 GENERAL SPECIFICATIONS

Item	Specification	Unit	Note
Active Area	409.8 (H) x 230.4(V) (18.5" diagonal)	mm	(1)
Bezel Opening Area	413.4(H) x 234 (V)	mm	
Driver Element	a-Si TFT active matrix	-	-
Pixel Number	1366 x R.G.B. x 768	pixel	-
Pixel Pitch	0.3 (H) x 0.3 (V)	mm	-
Pixel Arrangement	RGB vertical stripe	-	-
Display Colors	16.7M	color	-
Color gamut	72% by CIE1931 and 85% by CIE 1976		
Transmissive Mode	Normally White	-	-
Surface Treatment	AG type, 3H hard coating, Haze 25	-	-
Module Power Consumption	14.4	Watt	(2)

### 1.5 MECHANICAL SPECIFICATIONS

Item	Min.	Typ.	Max.	Unit	Note	
Module Size	Horizontal(H)	429.87	430.37	430.87	mm	(1)
	Vertical(V)	254.1	254.6	255.1	mm	
	Depth(D)	15.75	16.25	16.75	mm	
Weight	-	1965	2000	g	-	

Note (1) Please refer to the attached drawings for more information of front and back outline dimensions.

Note (2) Please refer to sec. 3.1 & 3.2 in this document for more information of power consumption

## 2. ABSOLUTE MAXIMUM RATINGS

### 2.1 ABSOLUTE RATINGS OF ENVIRONMENT

Item	Symbol	Value		Unit	Note
		Min.	Max.		
Storage Temperature	T <sub>ST</sub>	-20	60	°C	(1)
Operating Ambient Temperature	T <sub>OP</sub>	0	50	°C	(1), (2)
Shock (Non-Operating)	S <sub>NOP</sub>	-	50	G	(3), (5)
Vibration (Non-Operating)	V <sub>NOP</sub>	-	1.5	G	(4), (5)

Note (1) Temperature and relative humidity range is shown in the figure below.

- (a) 90 %RH Max. ( $T_a \leq 40$  °C).
- (b) Wet-bulb temperature should be 39 °C Max. ( $T_a > 40$  °C).
- (c) No condensation.

Note (2) The temperature of panel display surface area should be 0 °C Min. and 60 °C Max.

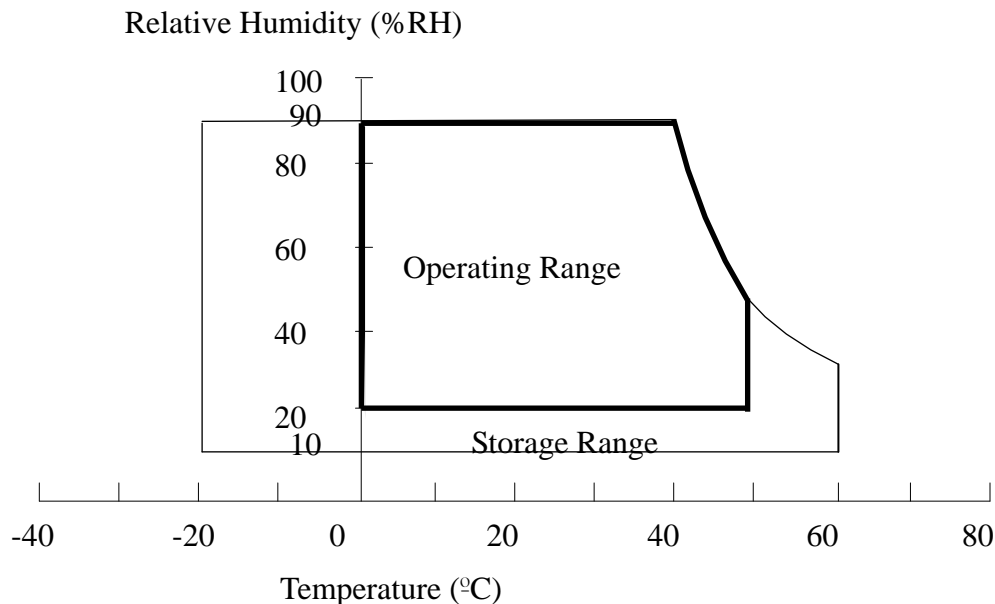

Note (3) 50G,11ms, half sine wave, 1 time for ± X, ± Y, ± Z.

Note (4) 10 ~ 300 Hz, 10min/cycle, 3 cycles each X, Y, Z.

Note (5) At testing Vibration and Shock, the fixture in holding the module has to be hard and rigid enough so that the module would not be twisted or bent by the fixture.

The fixing condition is shown as below:

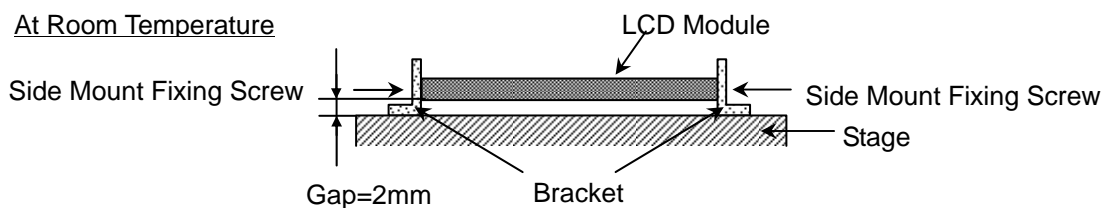

## 2.2 ELECTRICAL ABSOLUTE RATINGS

### 2.2.1 TFT LCD MODULE

Item	Symbol	Value		Unit	Note
		Min.	Max.		
Power Supply Voltage	Vcc	-0.3	+6.0	V	(1)

### 2.2.2 BACKLIGHT UNIT

Item	Symbol	Value		Unit	Note
		Min.	Max.		
Lamp Voltage	$V_L$	-	2.5K	$V_{RMS}$	(1), (2), $I_L = 7.5mA$
Lamp Current	$I_L$	2.0	8.0	$mA_{RMS}$	(1), (2)
Lamp Frequency	$F_L$	40	80	KHZ	

Note (1) Permanent damage to the device may occur if maximum values are exceeded. Function operation should be restricted to the conditions described under Normal Operating Conditions.

Note (2) Specified values are for lamp (Refer to 3.2 for further information).

### 3. ELECTRICAL CHARACTERISTICS

#### 3.1.1 TFT LCD MODULE

Ta = 25 ± 2 °C

Parameter	Symbol	Value			Unit	Note
		Min.	Typ.	Max.		
Power Supply Voltage	V <sub>CC</sub>	4.5	5.0	5.5	V	-
Ripple Voltage	V <sub>RP</sub>	-	-	100	mV	-
Rush Current	I <sub>RUSH</sub>	-	2	3	A	(2)
Power Supply Current	White	-	0.44	0.6	A	(3)a
	Black	-	0.58	0.9	A	(3)b
	Vertical Stripe	-	0.6	0.9	A	(3)c
Power Consumption		-	3.0	4.5	Watt	(4)
LVDS differential input voltage	V <sub>id</sub>	100	-	600	mV	
LVDS common input voltage	V <sub>ic</sub>	-	1.2	-	V	

Note (1) The module should be always operated within above ranges.

Note (2) Measurement Conditions:

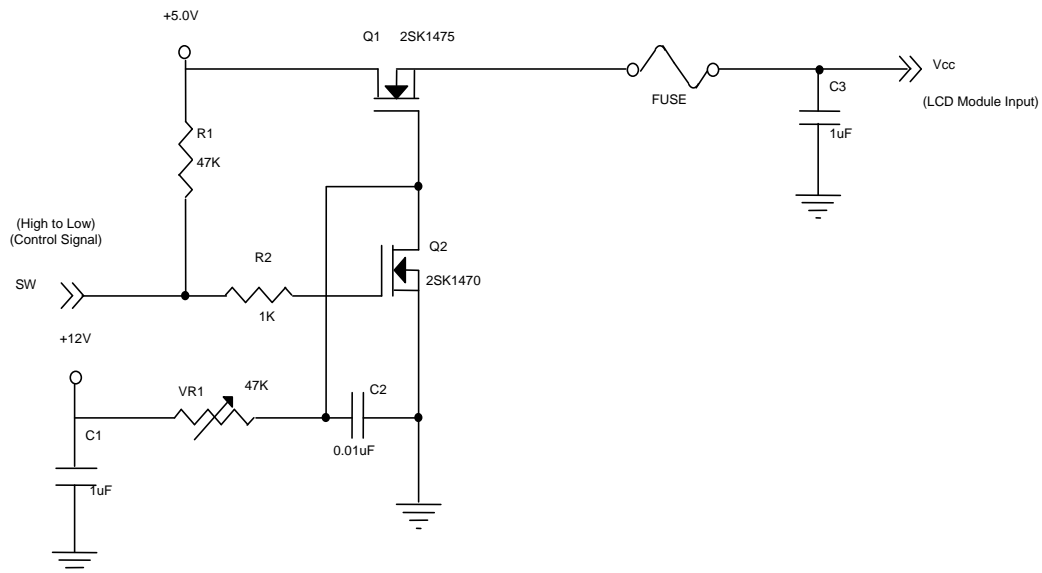

**V<sub>cc</sub> rising time is 470μs**

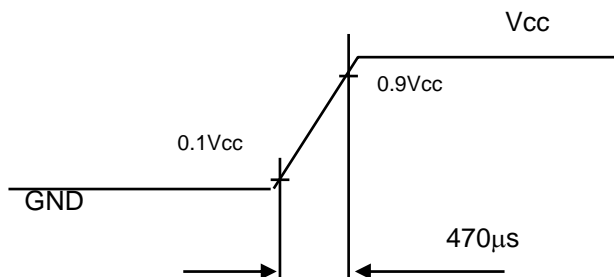

Note (3) The specified power supply current is under the conditions at  $V_{cc} = 5.0\text{ V}$ ,  $T_a = 25 \pm 2\text{ }^\circ\text{C}$ ,  $f_v = 60\text{ Hz}$ , whereas a power dissipation check pattern below is displayed.

a. White Pattern

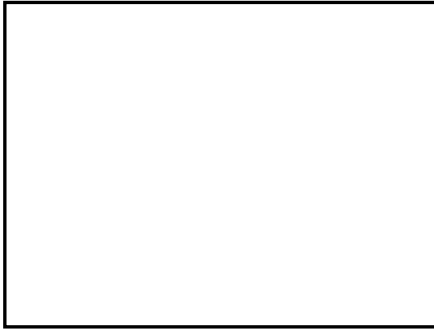

Active Area

b. Black Pattern



Active Area

c. Vertical Stripe Pattern

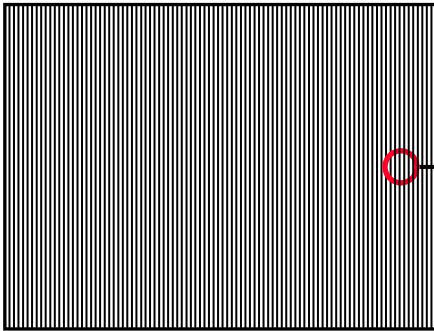

Active Area

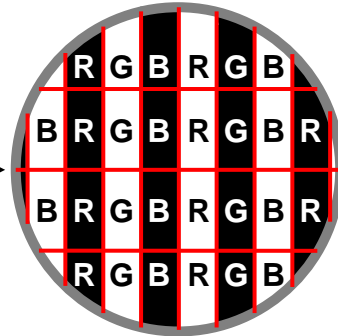

Note (4) The power consumption is specified at the pattern with the maximum current.

### 3.1.2 Vcc Power Dip Condition:

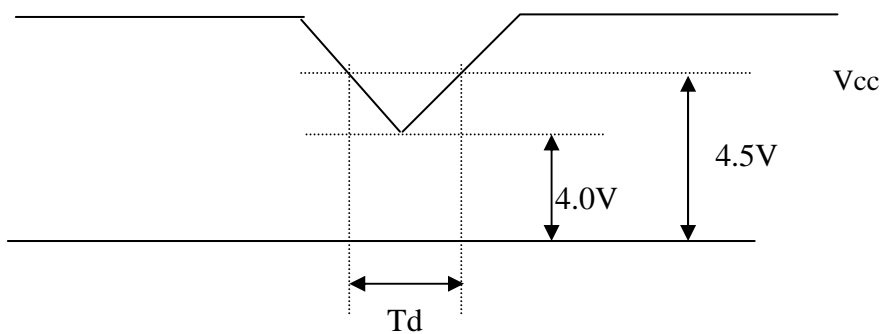

Dip condition:  $4.0\text{ V} \leq V_{cc} \leq 4.5\text{ V}$ ,  $T_d \leq 20\text{ ms}$



### 3.2 BACKLIGHT UNIT

Ta = 25 ± 2 °C

Parameter	Symbol	Value			Unit	Note
		Min.	Typ.	Max.		
Lamp Input Voltage	V <sub>L</sub>	---	760	836	V <sub>RMS</sub>	I <sub>L</sub> = 7.5 mA
Lamp Current	I <sub>L</sub>	2.0	7.5	8.0	mA <sub>RMS</sub>	(1)
Lamp Turn On Voltage	V <sub>s</sub>	---	---	1680(0°C)	V <sub>RMS</sub>	(2)
		---	---	1460(25°C)	V <sub>RMS</sub>	(2)
Operating Frequency	F <sub>L</sub>	40	---	80	KHz	(3)
Lamp Life Time	L <sub>BL</sub>	40000	---	---	Hrs	(5), I <sub>L</sub> = 7.5mA
Power Consumption	P <sub>L</sub>	---	11.4	---	W	(4), I <sub>L</sub> = 7.5 mA

Note (1) Lamp current is measured by current amplify & oscilloscope as shown below:

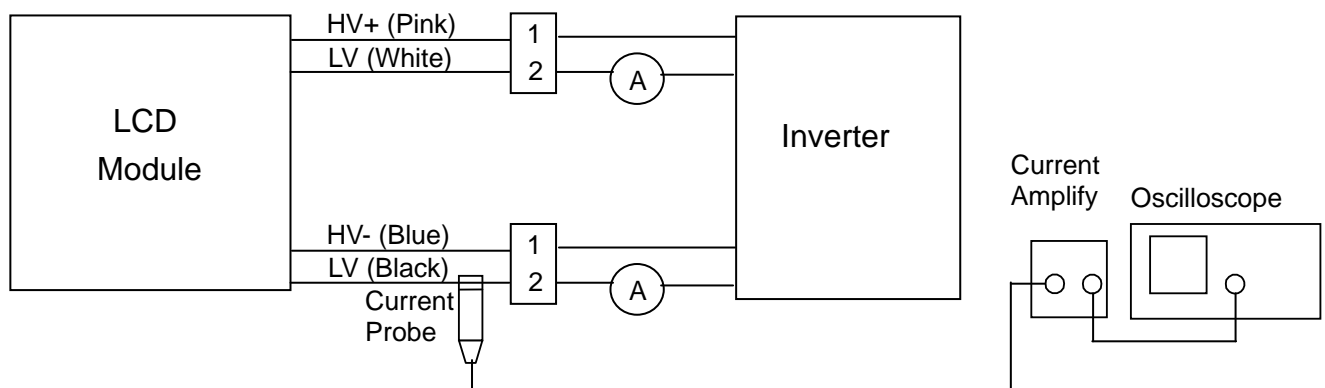

Measure equipment:  
 Current Amplify: Tektronix TCPA300  
 Current probe: Tektronix TCP312  
 Oscilloscope: TDS3054B

Note (2) The voltage that must be larger than V<sub>s</sub> should be applied to the lamp for more than 1 second after startup. Otherwise, the lamp may not be turned on normally. It is the value output voltage of NF circuit.

Note (3) The lamp frequency may produce interference with horizontal synchronization frequency from the display, which might cause line flow on the display. In order to avoid interference, the lamp frequency should be detached from the horizontal synchronization frequency and its harmonics as far as possible.

Note (4)  $P_L = I_L \times V_L \times 2$  (for 2 lamps)

Note (5) The lifetime of lamp can be defined as the time in which it continues to operate under the condition Ta = 25 ± 2 °C and (I<sub>L</sub> = 7.5 mA<sub>RMS</sub>) until one of the following events occurs:

- (a) When the brightness becomes ≤ 50% of its original value.
- (b) Effective lighting length decreases 80% under for initial. (Effective lighting length is a scope of luminance 80% over for average luminance at several point in lamp center.)

Note (6) The waveform of the voltage output of inverter must be area-symmetric and the design of the inverter must have specifications for the modularized lamp. The performance of the Backlight,

such as lifetime or brightness, is greatly influenced by the characteristics of the DC-AC inverter for the lamp. All the parameters of an inverter should be carefully designed to avoid producing too much current leakage from high voltage output of the inverter. When designing or ordering the inverter please make sure that a poor lighting caused by the mismatch of the Backlight and the inverter (miss-lighting, flicker, etc.) never occurs. If the above situation is confirmed, the module should be operated in the same manners when it is installed in your instrument.

The output of the inverter must have symmetrical (negative and positive) voltage waveform and symmetrical current waveform. (Unsymmetrical ratio is less than 10%) Please do not use the inverter which has unsymmetrical voltage and unsymmetrical current and spike wave. Lamp frequency may produce interface with horizontal synchronous frequency and as a result this may cause beat on the display. Therefore lamp frequency shall be as away possible from the horizontal synchronous frequency and from its harmonics in order to prevent interference.

Requirements for a system inverter design, which is intended to have a better display performance, a better power efficiency and a more reliable lamp. It shall help increase the lamp lifetime and reduce its leakage current.

- The asymmetry rate of the inverter waveform should be 10% below;
- The distortion rate of the waveform should be within  $\sqrt{2} \pm 10\%$ ;
- The ideal sine wave form shall be symmetric in positive and negative polarities

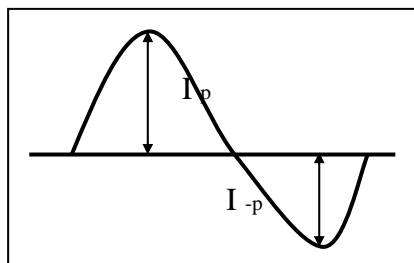

\* Asymmetry rate:

$$| I_p - I_{-p} | / I_{rms} * 100\%$$

\* Distortion rate

$$I_p \text{ (or } I_{-p}) / I_{rms}$$

4. BLOCK DIAGRAM

4.1 TFT LCD MODULE

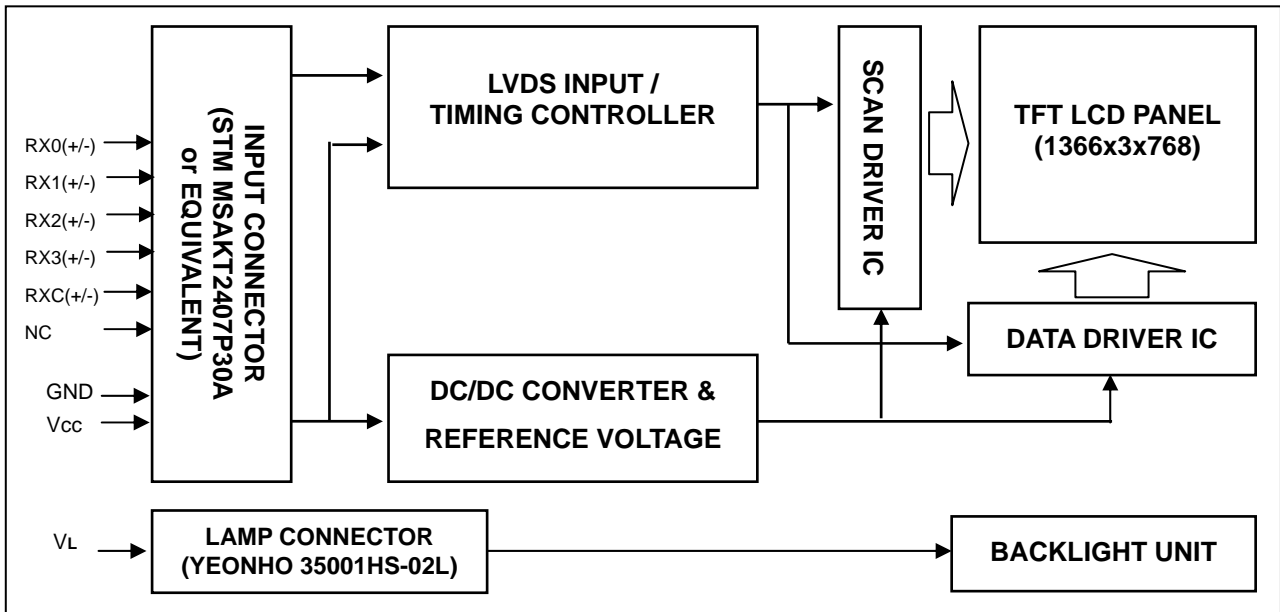

4.2 BACKLIGHT UNIT

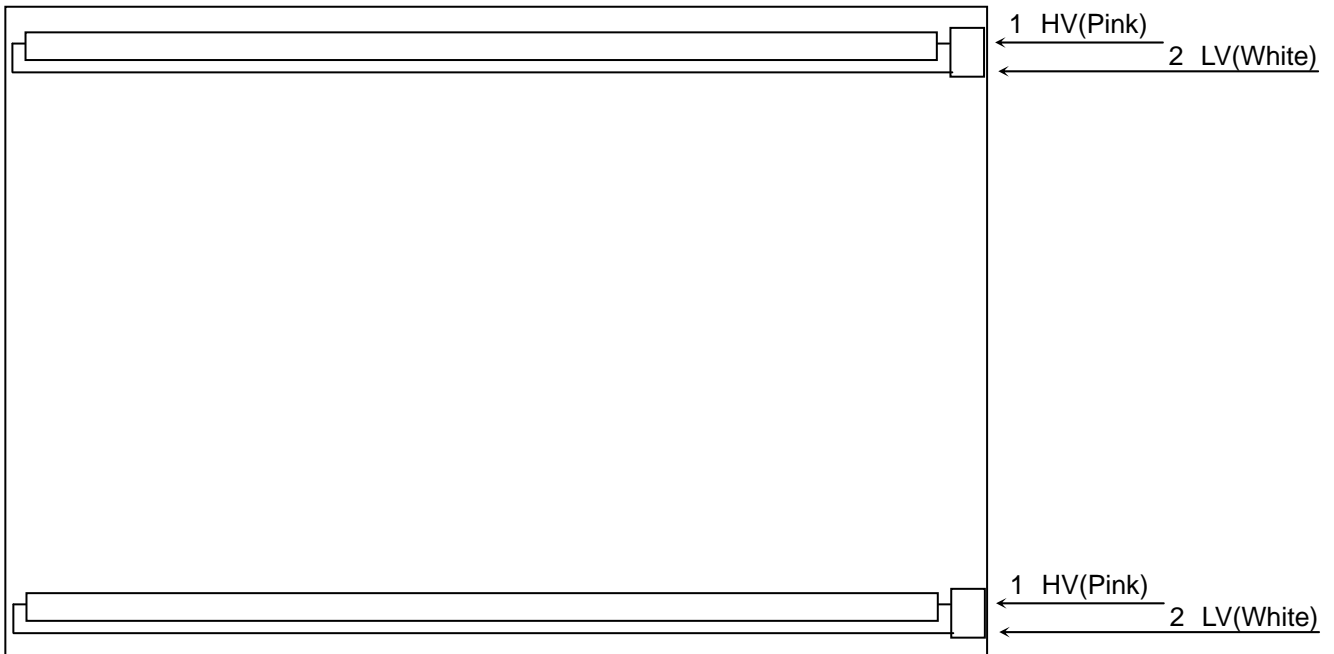

Note : On the same side, the same polarity lamp voltage design for lamps is recommended.

## 5. INPUT TERMINAL PIN ASSIGNMENT

### 5.1 TFT LCD MODULE

Pin	Name	Description
1	NC	Not connection, this pin should be open.
2	NC	Not connection, this pin should be open.
3	NC	Not connection, this pin should be open.
4	GND	Ground
5	RX0-	Negative LVDS differential data input. Channel 0
6	RX0+	Positive LVDS differential data input. Channel 0
7	GND	Ground
8	RX1-	Negative LVDS differential data input. Channel 1
9	RX1+	Positive LVDS differential data input. Channel 1
10	GND	Ground
11	RX2-	Negative LVDS differential data input. Channel 2
12	RX2+	Positive LVDS differential data input. Channel 2
13	GND	Ground
14	RXCLK-	Negative LVDS differential clock input.
15	RXCLK+	Positive LVDS differential clock input.
16	GND	Ground
17	RX3-	Negative LVDS differential data input. Channel 3
18	RX3+	Positive LVDS differential data input. Channel 3
19	GND	Ground
20	NC	Not connection, this pin should be open.
21	NC	Not connection, this pin should be open.
22	NC	Not connection, this pin should be open.
23	GND	Ground
24	GND	Ground
25	GND	Ground
26	Vcc	+5.0V power supply
27	Vcc	+5.0V power supply
28	Vcc	+5.0V power supply
29	Vcc	+5.0V power supply
30	Vcc	+5.0V power supply

Note (1) Connector Part No.: STM MSAKT2407P30A or equivalent

5.2 LVDS mapping table

LVDS Channel 0	LVDS output	D7	D6	D4	D3	D2	D1	D0
	Data order	G0	R5	R4	R3	R2	R1	R0
LVDS Channel 1	LVDS output	D18	D15	D14	D13	D12	D9	D8
	Data order	B1	B0	G5	G4	G3	G2	G1
LVDS Channel 2	LVDS output	D26	D25	D24	D22	D21	D20	D19
	Data order	DE	NA	NA	B5	B4	B3	B2
LVDS Channel 3	LVDS output	D23	D17	D16	D11	D10	D5	D27
	Data order	NA	B7	B6	G7	G6	R7	R6

5.3 BACKLIGHT UNIT:

Pin	Symbol	Description	Remark
1	HV	High Voltage	Pink
2	LV	Low Voltage	White

Note (1) Connector Part No.: YEONHO 35001HS-02L or equivalent

### 5.4 COLOR DATA INPUT ASSIGNMENT

The brightness of each primary color (red, green and blue) is based on the 8-bit gray scale data input for the color. The higher the binary input, the brighter the color. The table below provides the assignment of color versus data input.

Color		Data Signal																							
		Red								Green								Blue							
		R7	R6	R5	R4	R3	R2	R1	R0	G7	G6	G5	G4	G3	G2	G1	G0	B7	B6	B5	B4	B3	B2	B1	B0
Basic Colors	Black	0	0	0	0	0	0	0	0	0	0	0	0	0	0	0	0	0	0	0	0	0	0	0	0
	Red	1	1	1	1	1	1	1	1	0	0	0	0	0	0	0	0	0	0	0	0	0	0	0	0
	Green	0	0	0	0	0	0	0	0	1	1	1	1	1	1	1	1	0	0	0	0	0	0	0	0
	Blue	0	0	0	0	0	0	0	0	0	0	0	0	0	0	0	0	1	1	1	1	1	1	1	1
	Cyan	0	0	0	0	0	0	0	0	1	1	1	1	1	1	1	1	1	1	1	1	1	1	1	1
	Magenta	1	1	1	1	1	1	1	1	0	0	0	0	0	0	0	0	1	1	1	1	1	1	1	1
	Yellow	1	1	1	1	1	1	1	1	1	1	1	1	1	1	1	1	0	0	0	0	0	0	0	0
	White	1	1	1	1	1	1	1	1	1	1	1	1	1	1	1	1	1	1	1	1	1	1	1	1
Gray Scale Of Red	Red(0) / Dark	0	0	0	0	0	0	0	0	0	0	0	0	0	0	0	0	0	0	0	0	0	0	0	0
	Red(1)	0	0	0	0	0	0	0	1	0	0	0	0	0	0	0	0	0	0	0	0	0	0	0	0
	Red(2)	0	0	0	0	0	0	1	0	0	0	0	0	0	0	0	0	0	0	0	0	0	0	0	0
	:	:	:	:	:	:	:	:	:	:	:	:	:	:	:	:	:	:	:	:	:	:	:	:	:
	:	:	:	:	:	:	:	:	:	:	:	:	:	:	:	:	:	:	:	:	:	:	:	:	:
	:	:	:	:	:	:	:	:	:	:	:	:	:	:	:	:	:	:	:	:	:	:	:	:	:
	Red(253)	1	1	1	1	1	1	0	1	0	0	0	0	0	0	0	0	0	0	0	0	0	0	0	0
	Red(254)	1	1	1	1	1	1	1	0	0	0	0	0	0	0	0	0	0	0	0	0	0	0	0	0
Red(255)	1	1	1	1	1	1	1	1	0	0	0	0	0	0	0	0	0	0	0	0	0	0	0	0	
Gray Scale Of Green	Green(0) / Dark	0	0	0	0	0	0	0	0	0	0	0	0	0	0	0	0	0	0	0	0	0	0	0	0
	Green(1)	0	0	0	0	0	0	0	0	0	0	0	0	0	0	1	0	0	0	0	0	0	0	0	0
	Green(2)	0	0	0	0	0	0	0	0	0	0	0	0	0	1	0	0	0	0	0	0	0	0	0	0
	:	:	:	:	:	:	:	:	:	:	:	:	:	:	:	:	:	:	:	:	:	:	:	:	:
	:	:	:	:	:	:	:	:	:	:	:	:	:	:	:	:	:	:	:	:	:	:	:	:	:
	:	:	:	:	:	:	:	:	:	:	:	:	:	:	:	:	:	:	:	:	:	:	:	:	:
	Green(253)	0	0	0	0	0	0	0	1	1	1	1	1	1	1	0	1	0	0	0	0	0	0	0	0
	Green(254)	0	0	0	0	0	0	0	1	1	1	1	1	1	1	1	0	0	0	0	0	0	0	0	0
Green(255)	0	0	0	0	0	0	0	1	1	1	1	1	1	1	1	1	0	0	0	0	0	0	0	0	
Gray Scale Of Blue	Blue(0) / Dark	0	0	0	0	0	0	0	0	0	0	0	0	0	0	0	0	0	0	0	0	0	0	0	0
	Blue(1)	0	0	0	0	0	0	0	0	0	0	0	0	0	0	0	0	0	0	0	0	0	0	0	1
	Blue(2)	0	0	0	0	0	0	0	0	0	0	0	0	0	0	0	0	0	0	0	0	0	0	1	0
	:	:	:	:	:	:	:	:	:	:	:	:	:	:	:	:	:	:	:	:	:	:	:	:	:
	:	:	:	:	:	:	:	:	:	:	:	:	:	:	:	:	:	:	:	:	:	:	:	:	:
	:	:	:	:	:	:	:	:	:	:	:	:	:	:	:	:	:	:	:	:	:	:	:	:	:
	Blue(253)	0	0	0	0	0	0	0	0	0	0	0	0	0	0	0	1	1	1	1	1	1	1	0	1
	Blue(254)	0	0	0	0	0	0	0	0	0	0	0	0	0	0	0	1	1	1	1	1	1	1	1	0
Blue(255)	0	0	0	0	0	0	0	0	0	0	0	0	0	0	0	1	1	1	1	1	1	1	1	1	

Note (1) 0: Low Level Voltage, 1: High Level Voltage

## 6. INTERFACE TIMING

### 6.1 INPUT SIGNAL TIMING SPECIFICATIONS

The input signal timing specifications are shown as the following table and timing diagram.

Signal	Item	Symbol	Min.	Typ.	Max.	Unit	Note
LVDS Clock	Frequency	$F_c$	50.0	76	95	MHz	-
	Period	$T_c$	10.5	13.2	20	ns	-
	High Time	$T_{ch}$	-	4/7	-	$T_c$	-
	Low Time	$T_{cl}$	-	3/7	-	$T_c$	-
LVDS Data	Setup Time	$T_{lvs}$	600	-	-	ps	-
	Hold Time	$T_{lvh}$	600	-	-	ps	-
Vertical Active Display Term	Frame Rate	$F_r$	40	60	75	Hz	$T_v = T_{vd} + T_{vb}$
	Total	$T_v$	778	806	888	$T_h$	-
	Display	$T_{vd}$	768	768	768	$T_h$	-
	Blank	$T_{vb}$	$T_v - T_{vd}$	38	$T_v - T_{vd}$	$T_h$	-
Horizontal Active Display Term	Total	$T_h$	1446	1560	1936	$T_c$	$T_h = T_{hd} + T_{hb}$
	Display	$T_{hd}$	1366	1366	1366	$T_c$	-
	Blank	$T_{hb}$	$T_h - T_{hd}$	194	$T_h - T_{hd}$	$T_c$	-

Note: Because this module is operated by DE only mode, Hsync and Vsync input signals should be set to low logic level or ground. Otherwise, this module would operate abnormally.

#### INPUT SIGNAL TIMING DIAGRAM

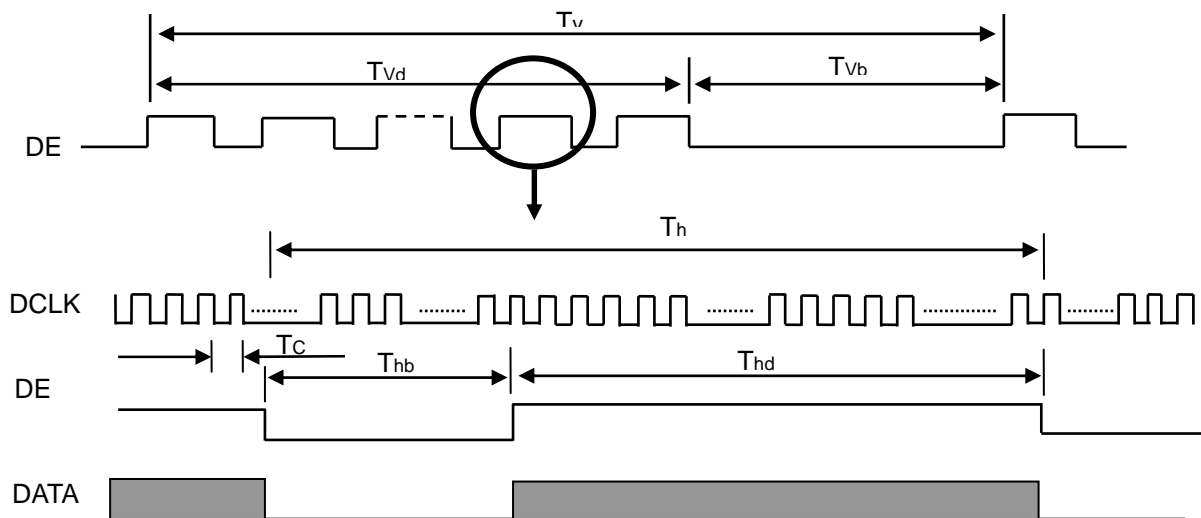

## 6.2 POWER ON/OFF SEQUENCE

To prevent a latch-up or DC operation of LCD module, the power on/off sequence should be as the diagram below.

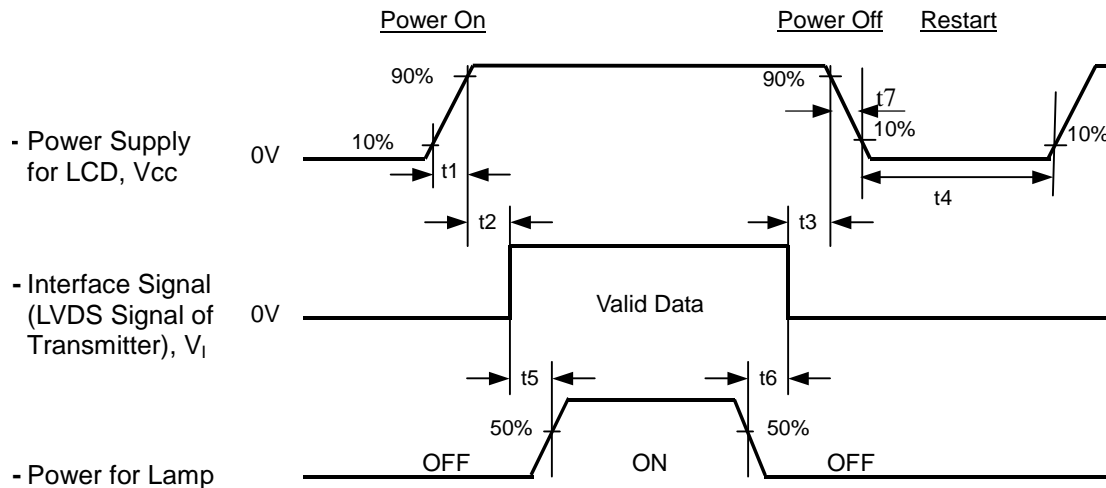

### Timing Specifications:

- $0.5 < t1 \leq 10 \text{ msec}$
- $0 < t2 \leq 50 \text{ msec}$
- $0 < t3 \leq 50 \text{ msec}$
- $t4 \geq 500 \text{ msec}$
- $t5 \geq 450 \text{ msec}$
- $t6 \geq 90 \text{ msec}$
- $5 \leq t7 \leq 100 \text{ msec}$

### Note.

- (1) The supply voltage of the external system for the module input should be the same as the definition of Vcc.
- (2) Apply the lamp voltage within the LCD operation range. When the backlight turns on before the LCD operation of the LCD turns off, the display may momentarily become abnormal screen.
- (3) In case of VCC = off level, please keep the level of input signals on the low or keep a high impedance.
- (4) T4 should be measured after the module has been fully discharged between power off and on period.
- (5) Interface signal shall not be kept at high impedance when the power is on.
- (6) The company will not guarantee or compensate for the product damage caused by not following the Power Sequence.



## 7. OPTICAL CHARACTERISTICS

### 7.1 TEST CONDITIONS

Item	Symbol	Value	Unit
Ambient Temperature	Ta	25±2	°C
Ambient Humidity	Ha	50±10	%RH
Supply Voltage	V <sub>CC</sub>	5V	V
Input Signal	According to typical value in "3. ELECTRICAL CHARACTERISTICS"		
Lamp Current	I <sub>L</sub>	7.5 ± 0.5	mA
Inverter Operating Frequency	F <sub>L</sub>	55±5	KHz
Inverter	Logah MIT70070.50		

### 7.2 OPTICAL SPECIFICATIONS

The relative measurement methods of optical characteristics are shown in 7.2. The following items should be measured under the test conditions described in 7.1 and stable environment shown in Note (5).

Item	Symbol	Condition	Min.	Typ.	Max.	Unit	Note	
Color Chromaticity (CIE 1931)	Red	Rx	θ <sub>x</sub> =0°, θ <sub>y</sub> =0° CS-1000T	Typ - 0.03	0.646	Typ + 0.03	-	(1), (5)
		Ry			0.334			
	Green	Gx			0.284			
		Gy			0.602			
	Blue	Bx			0.152			
		By			0.076			
	White	Wx			0.313			
		Wy			0.329			
	Center Luminance of White (Center of Screen)	L <sub>C</sub>						
Contrast Ratio	CR		700	1000	-	-	(2), (5)	
Response Time	T <sub>R</sub>	θ <sub>x</sub> =0°, θ <sub>y</sub> =0°	-	1.3	3.2	ms	(3)	
	T <sub>F</sub>		-	3.7	6.8			
White Variation	δW	θ <sub>x</sub> =0°, θ <sub>y</sub> =0° USB2000	-	1.3	1.42	-	(5), (6)	
Viewing Angle	Horizontal	θ <sub>x+</sub>	CR ≥ 10 USB2000	75	85	-	Deg.	(1), (5)
		θ <sub>x-</sub>		75	85	-		
	Vertical	θ <sub>y+</sub>		70	80	-		
		θ <sub>y-</sub>		70	80	-		

Note (1) Definition of Viewing Angle ( $\theta_x, \theta_y$ ):

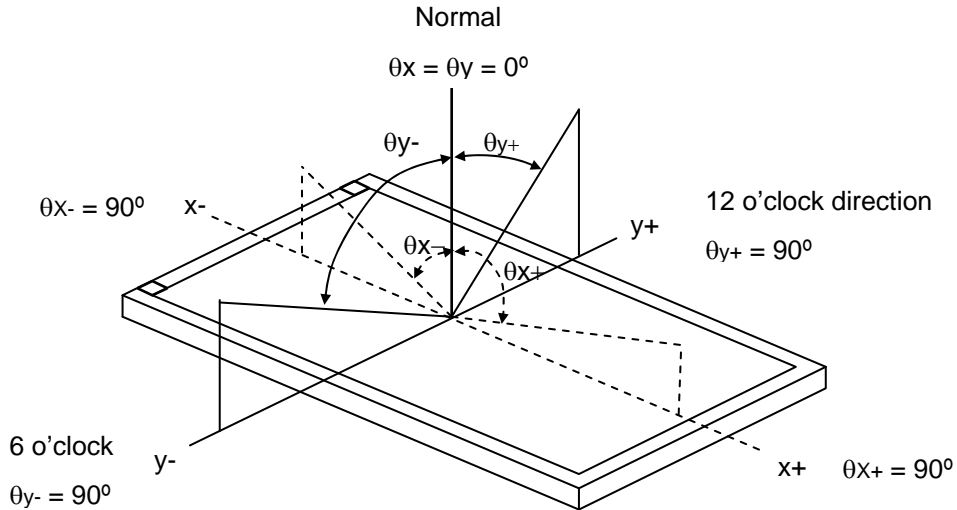

Note (2) Definition of Contrast Ratio (CR):

The contrast ratio can be calculated by the following expression.

$$\text{Contrast Ratio (CR)} = L_{255} / L_0$$

L255: Luminance of gray level 255

L 0: Luminance of gray level 0

$$\text{CR} = \text{CR (5)}$$

CR (X) is corresponding to the Contrast Ratio of the point X at Figure in Note (6).

Note (3) Definition of Response Time ( $T_R, T_F$ ):

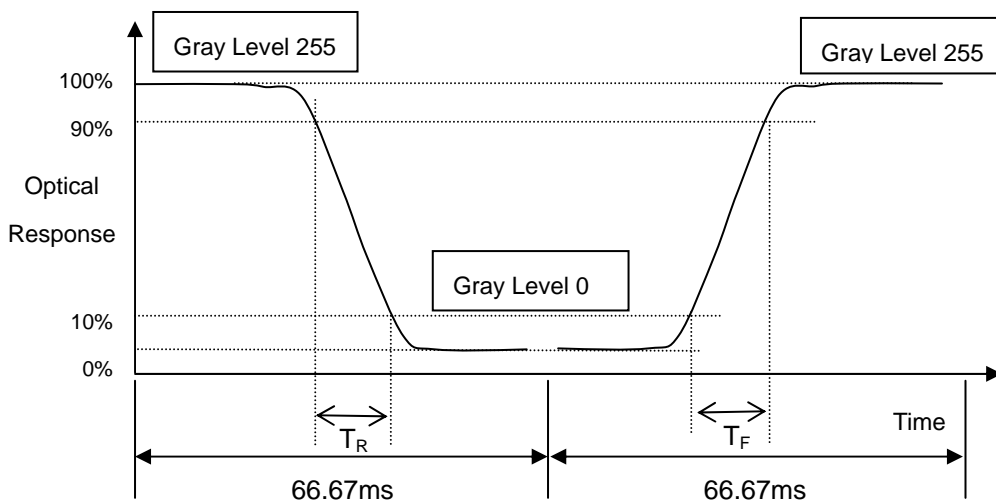

Note (4) Definition of Luminance of White ( $L_c$ ):

Measure the luminance of gray level 255 at center point

$$L_c = L(5)$$

$L(x)$  is corresponding to the luminance of the point X at Figure in Note (6).

Note (5) Measurement Setup:

The LCD module should be stabilized at given temperature for 20 minutes to avoid abrupt temperature change during measuring. In order to stabilize the luminance, the measurement should be executed after lighting Backlight for 20 minutes in a windless room.

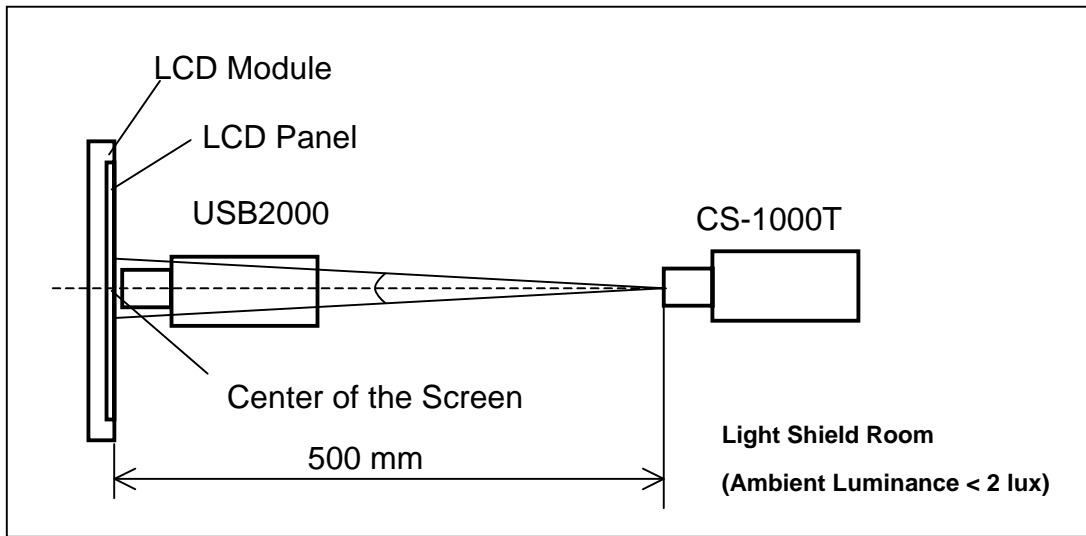

Note (6) Definition of White Variation ( $\delta W$ ):

Measure the luminance of gray level 255 at 9 points

$$\delta W = \text{Maximum} [L(1), L(2) \dots L(4), L(9)] / \text{Minimum} [L(1), L(2) \dots L(4), L(9)]$$

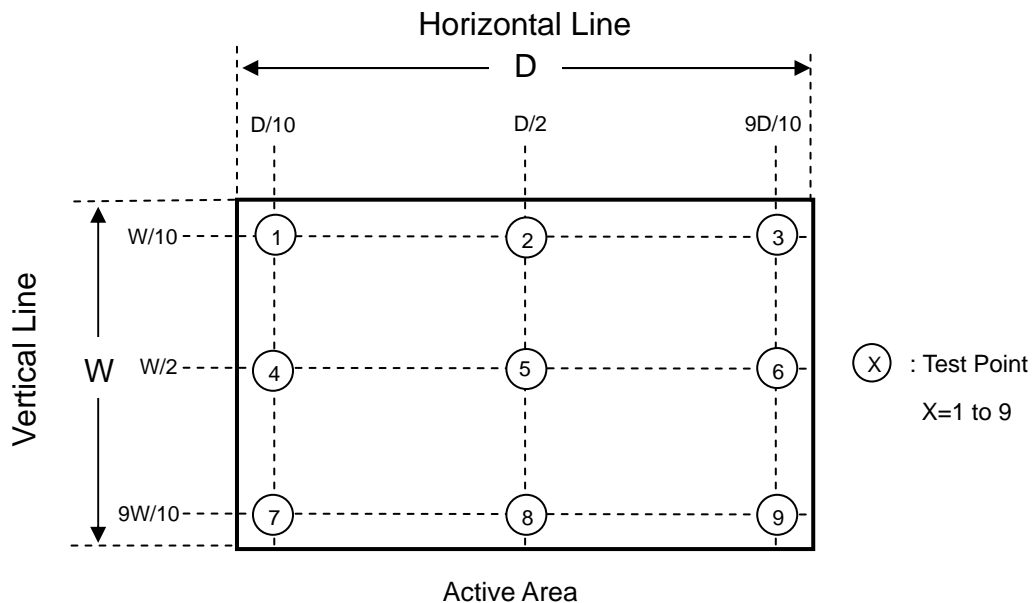

**8. PACKAGING :**

**8.1 PACKING SPECIFICATIONS**

- (1) 9 LCD modules / 1 Box
- (2) Box dimensions: 525(L) X 300 (W) X 360 (H) mm
- (3) Weight: 19.79 Kg (9 modules per box)
- (4) Desiccant ( Drier ) : Weight 30g / 1 piece, Cobalt chloride free.

**8.2 PACKING METHOD**

(1) Carton Packing should have no failure in the following reliability test items.

Test Item	Test Conditions	Note
Vibration	ISTA STANDARD Random, Frequency Range: 1 – 200 Hz Top & Bottom: 30 minutes (+Z), 10 min (-Z), Right & Left: 10 minutes (X) Back & Forth 10 minutes (Y)	Non Operation
Dropping Test	1 Corner, 3 Edge, 6 Face, ISTA STANDARD	Non Operation

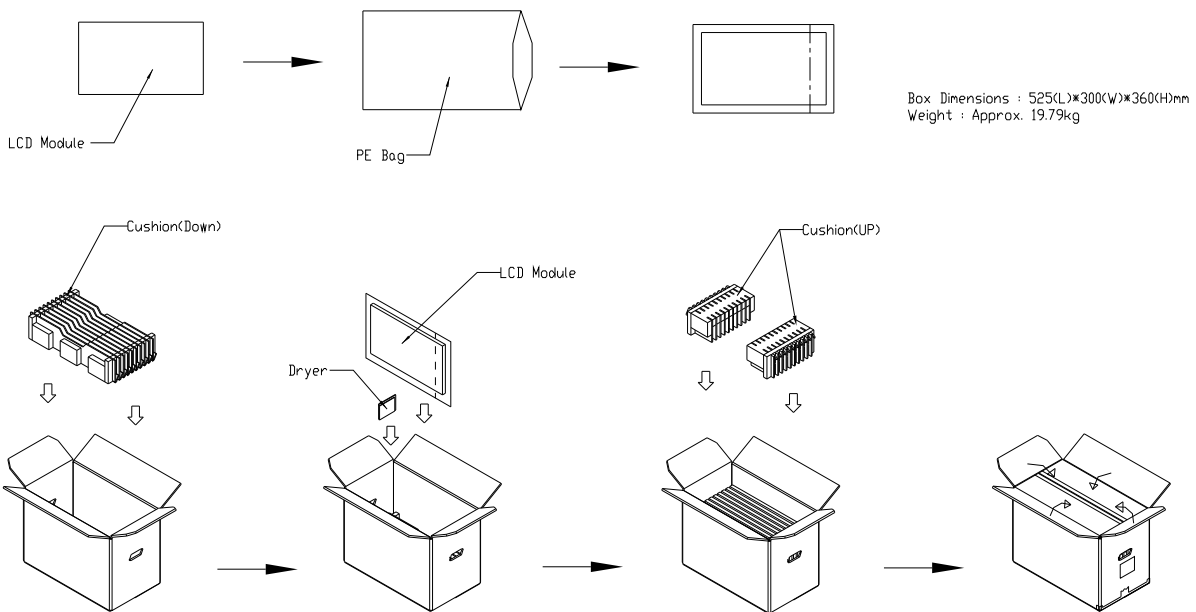

**Figure. 8-1 Packing method**

For ocean shipping

Sea / Land Transportation (40ft HQ Container)

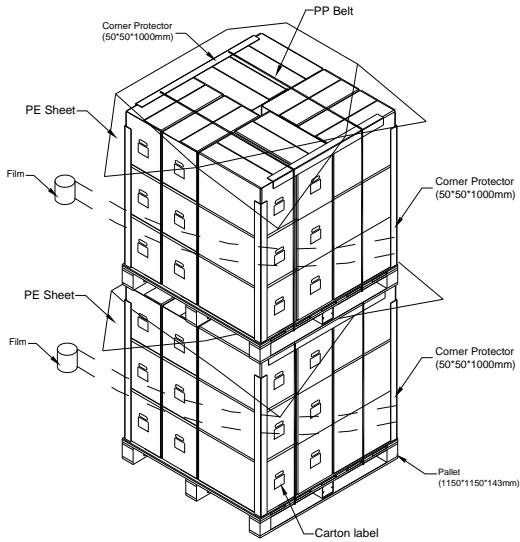

Sea / Land Transportation (40ft Container)

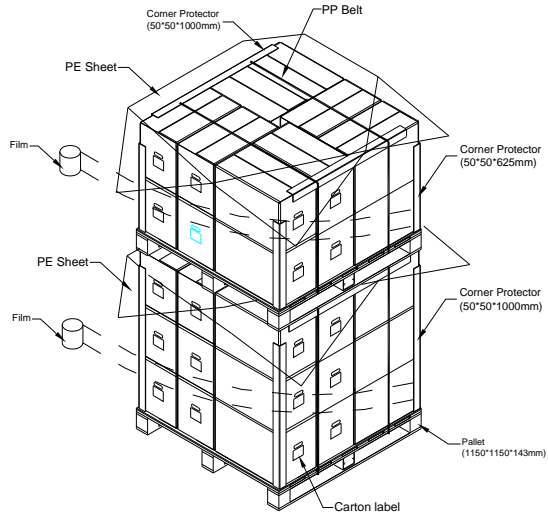

**Figure. 8-2 Packing method**

For air transport

Air Transportation

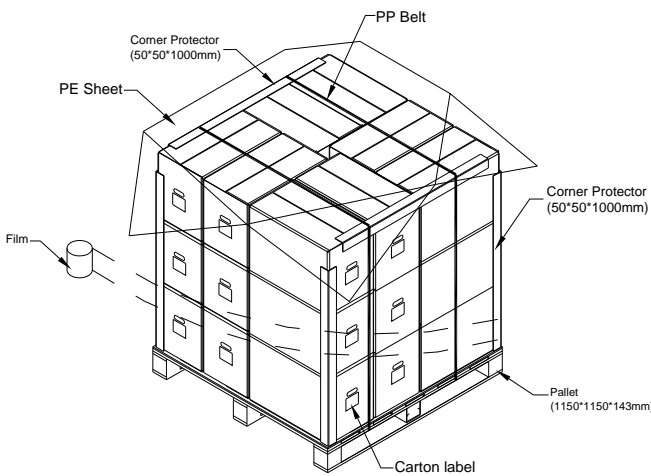

**Figure. 8-3 Packing method**

9. DEFINITION OF LABELS

9.1 CMO MODULE LABEL

The barcode nameplate is pasted on each module as illustration, and its definitions are as following explanation.



- (a) Model Name: M185B1-L02
- (b) Revision: Rev. XX, for example: A0, A1... B1, B2... or C1, C2...etc.
- (c) CMO barcode definition:

Serial ID: XX-XX-X-XX-YMD-L-NNNN

Code	Meaning	Description
XX	CMO internal use	-
XX	Revision	Cover all the change
X	CMO internal use	-
XX	CMO internal use	-
YMD	Year, month, day	Year: 2001=1, 2002=2, 2003=3, 2004=4... Month: 1~12=1, 2, 3, ~, 9, A, B, C Day: 1~31=1, 2, 3, ~, 9, A, B, C, ~, W, X, Y, exclude I, O, and U.
L	Product line #	Line 1=1, Line 2=2, Line 3=3, ...
NNNN	Serial number	Manufacturing sequence of product

- (d) Customer's barcode definition:

Serial ID: CM-18B12-X-X-X-XX-L-XX-L-YMD-NNNN

Code	Meaning	Description
CM	Supplier code	CMO=CM
18B12	Model number	M185B1-L02 = 18B12
X	Revision code	Non ZBD: 1,2,~,8,9 / ZBD: A~Z
X	Source driver IC	Century=1, CLL=2, Demos=3, Epson=4, Fujitsu=5, Himax=6, Hitachi=7, Hynix=8, LDI=9, Matsushita=A, NEC=B, Novatec=C, OKI=D, Philips=E, Renesas=F, Samsung=G, Sanyo=H, Sharp=I, TI=J, Topro=K, Toshiba=L,
X	Gate driver IC code	
XX	Cell location	Tainan Taiwan=TN, Ningbo China=NP
L	Cell line #	1,2,~,9,A,B,~,Y,Z
XX	Module location	Tainan Taiwan=TN ; Ningbo China=NP
L	Module line #	1,2,~,9,A,B,~,Y,Z
YMD	Year, month, day	Year: 2001=1, 2002=2, 2003=3, 2004=4... Month: 1~12=1, 2, 3, ~, 9, A, B, C Day: 1~31=1, 2, 3, ~, 9, A, B, C, ~, T, U, V
NNNN	Serial number	By LCD supplier

- (e) UL Factory ID:

Region	Factory ID
TWCMO	GEMN
NBCMO	LEOO
NBCME	CANO
NHCMO	CAPG

## 10. PRECAUTIONS

### 10.1 ASSEMBLY AND HANDLING PRECAUTIONS

- (1) Do not apply rough force such as bending or twisting to the module during assembly.
- (2) To assemble or install module into user's system can be only in clean working areas. The dust and oil may cause electrical short or worsen the polarizer.
- (3) It's not permitted to have pressure or impulse on the module because the LCD panel and Backlight will be damaged.
- (4) Always follow the correct power sequence when LCD module is connecting and operating. This can prevent damage to the CMOS LSI chips during latch-up.
- (5) Do not pull the I/F connector in or out while the module is operating.
- (6) Do not disassemble the module.
- (7) Use a soft dry cloth without chemicals for cleaning, because the surface of polarizer is very soft and easily scratched.
- (8) It is dangerous that moisture come into or contacted the LCD module, because moisture may damage LCD module when it is operating.
- (9) High temperature or humidity may reduce the performance of module. Please store LCD module within the specified storage conditions.
- (10) When ambient temperature is lower than 10°C may reduce the display quality. For example, the response time will become slowly, and the starting voltage of CCFL will be higher than room temperature.

### 10.2 SAFETY PRECAUTIONS

- (1) The startup voltage of Backlight is approximately 1000 Volts. It may cause electrical shock while assembling with inverter. Do not disassemble the module or insert anything into the Backlight unit.
- (2) If the liquid crystal material leaks from the panel, it should be kept away from the eyes or mouth. In case of contact with hands, skin or clothes, it has to be washed away thoroughly with soap.
- (3) After the module's end of life, it is not harmful in case of normal operation and storage.

### 10.3 SAFETY STANDARDS

The LCD module should be certified with safety regulations as follows:

- (1) UL60950-1 or updated standard.
- (2) IEC60950-1 or updated standard.

### 10.4 OTHER

When fixed patterns are displayed for a long time, remnant image is likely to occur.

## 11. MECHANICAL CHARACTERISTICS

[Refer to the next 2 pages]



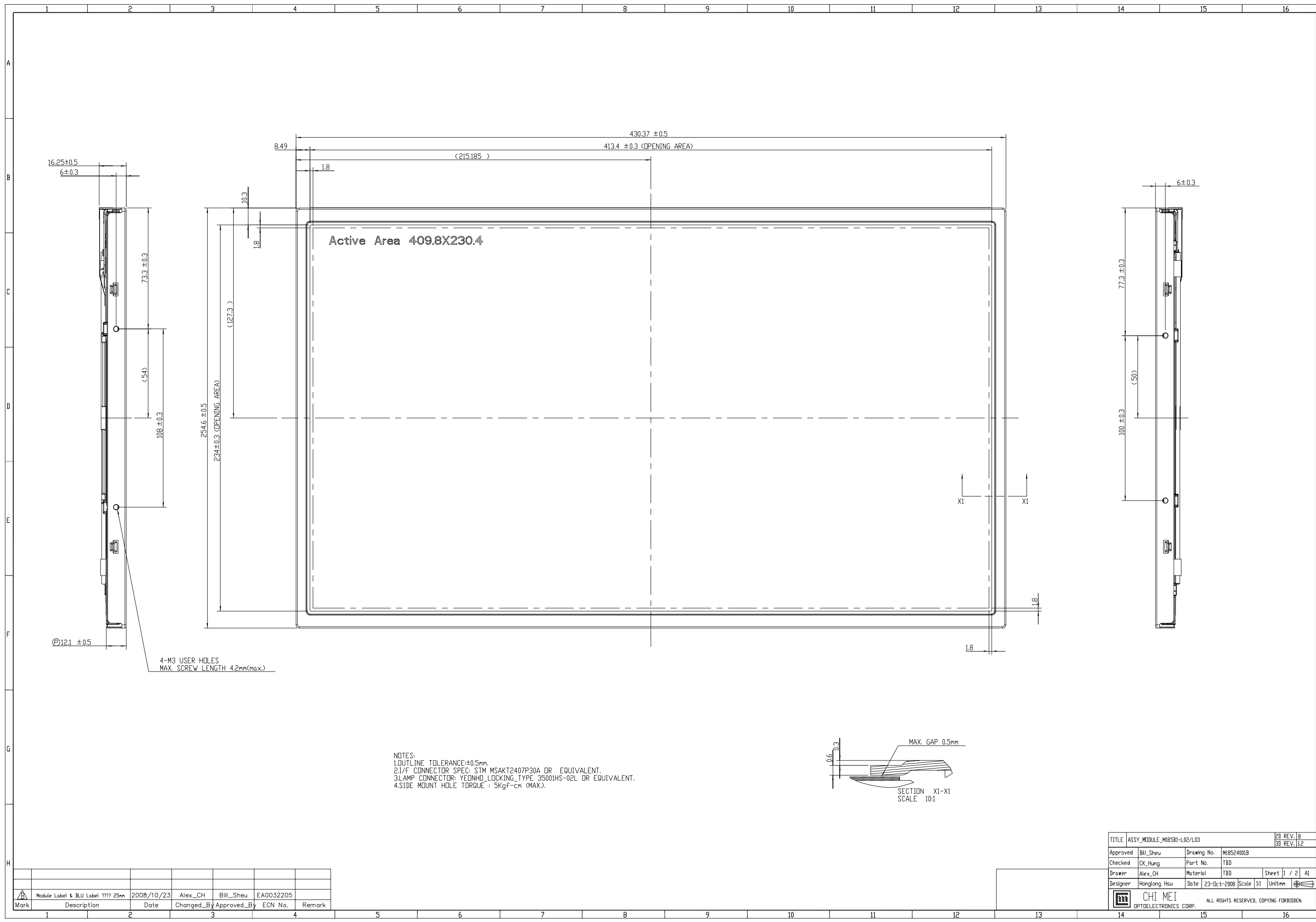

NOTES:  
 1. OUTLINE TOLERANCE: ±0.5mm.  
 2. I/F CONNECTOR SPEC: SIM MSAKT2407P30A OR EQUIVALENT.  
 3. LAMP CONNECTOR: YEDNHO\_LOCKING\_TYPE 35001HS-02L OR EQUIVALENT.  
 4. SIDE MOUNT HOLE TORQUE: 5Kgf-cm (MAX.).

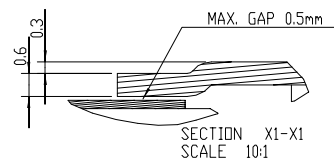

Mark	Description	Date	Changed_By	Approved_By	ECN No.	Remark
	Module Label & BLU Label ??? 25mm	2008/10/23	Alex_CH	Bill_Sheu	EA0032205	

TITLE	ASSY_MODULE_M185B1-L02/L03	2D REV. B	3D REV. 1.2
Approved	BIL_Sheu	Drawing No.	M18524001B
Checked	CK_Hung	Part No.	TBD
Drawer	Alex_CH	Material	TBD
Designer	Honglong Hsu	Date	23-Oct-2008
		Scale	1:1
		Unit	mm
		ALL RIGHTS RESERVED, COPYING FORBIDDEN.	

1 2 3 4 5 6 7 8 9 10 11 12 13 14 15 16

A

B

C

D

E

F

G

H

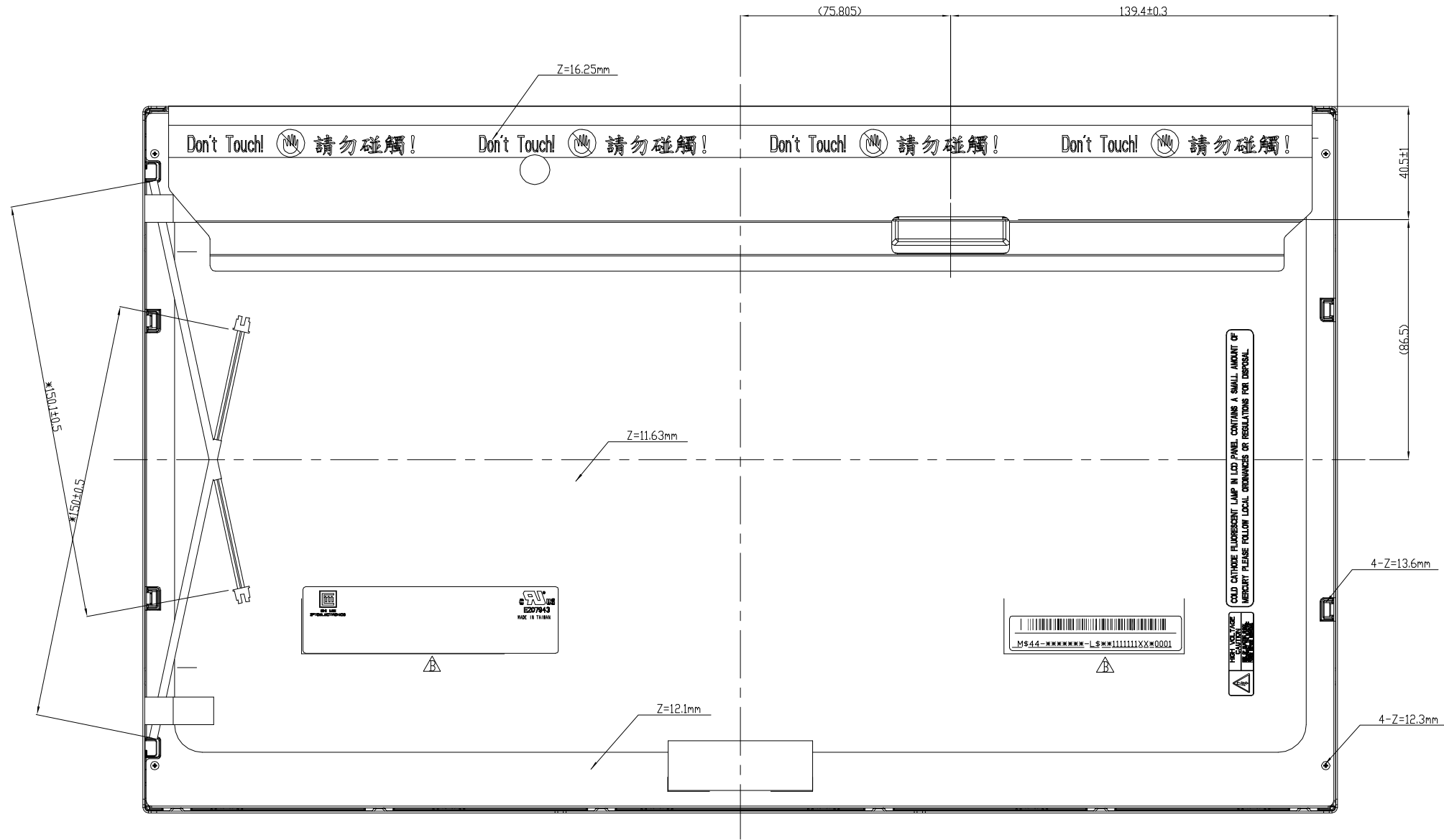

NOTES:  
 1. OUTLINE TOLERANCE: ±0.5mm.  
 2. I/F CONNECTOR SPEC: STM MSAKT2407P30A OR EQUIVALENT.  
 3. LAMP CONNECTOR: YEONHO\_LOCKING\_TYPE 3500HS-02L OR EQUIVALENT.  
 4. SIDE MOUNT HOLE TORQUE: 5kgf-cm(MAX.).

Mark	Description	Date	Changed_By	Approved_By	ECN No.	Remark
	Module Label & BLU Label ??? 25mm	2008/10/23	Alex_CH	Bill_Sheu	EA0032205	

TITLE	ASSY_MODULE_M185B1-L02/L03	2D REV. B	3D REV. 12
Approved	Bill_Sheu	Drawing No.	M18524001B
Checked	CK_Hung	Part No.	TBD
Drawer	Alex_CH	Material	TBD
Designer	Honglong Hsu	Date	23-Oct-2008
		Scale	1:1
		Unit	mm
		ALL RIGHTS RESERVED, COPYING FORBIDDEN.	

1 2 3 4 5 6 7 8 9 10 11 12 13 14 15 16